

A Smart Home Energy Consumption Monitoring System Integrated with Internet Connection

MULIADI^{1*}, M. YOGI FAHREZI², INTAN SARI ARENI², ELYAS PALANTEI², ANDANI ACHMAD²

¹Doctoral Student of Electrical Engineering Department, Universitas Hasanuddin

* Department of Electrical Education Engineering, Universitas Negeri Makassar

²Department of Electrical Engineering, Universitas Hasanuddin, Makassar, Indonesia

muliadi7404@unm.ac.id; {intan; elyas.palantei; andani}@unhas.ac.id

Abstract—The use of IoT technology enables web-based monitoring to statistically collect information related to measurements of electrical energy parameters, such as real time measurement of current (I), voltage (V) and power (P). This study aims to design a web-based real time monitoring system for electrical energy consumption inside a particular house. The sensing peripheral node was constructed using an ESP8266 controller chipset to steer a relay and a current sensor PZEM-004T. The controller was programmed using the Arduino IDE application and exploiting the powerful performance of C language to build the codes. The web-based application interface was correspondingly created using the sublime text 3-text editor using the HTML; CSS programming languages as the frontend; and both PHP and MySQL software as the backend. Users could control the functional of the particular installed electronic devices using ON / OFF button directly through the designed website. Through this way, users may also observe the current and power values consumed by each operated devices. The cumulative power consumption profile for a certain time interval for each electronic appliances is also graphically visualized on the website menu. The practical testing results obtained the percentage of error current reading from the PZEM-004T sensor to the theoretical current value. From the data collection of an electric loads, the error percentage of the light bulb load is 0.5%, the rice cooker load is 0.7% and the dispenser load is 0.1%.

Keywords— *Smart Home, IoT Network, Green Technology, Graphical Visualization, and Web-Server Application*

I. INTRODUCTION

The monitoring system is a routine process of collecting data and measuring the progress of the monitored object that focuses on the process and output. Monitoring will provide information about the status and trend of measurement and evaluation provided that occurs continuously which is generally carried out for a specific purpose, such as to check the process of an object and to evaluate certain conditions [1][2]. The energy monitoring system is expected to save energy so that there will be cost savings, increasing competitiveness and improving the quality of the environment. Energy monitoring and auditing is an alternative choice in energy efficiency [3][4].

Nowadays, the Internet of Things (IoT) is a popular supporting technology for monitoring systems because all devices are connected to the internet so that monitoring can be

carried out with no limitation of time and place [5-12]. This technology enables the development of smart devices, such as smart laboratories, smart homes, and smart cities. One of IoT vital components is a sensor. It is connected to a controller so that the parameters that are monitored and analyzed can be seen in real-time [6]. This means that IoT enables to communicate with system devices and use device data for control and monitoring [5].

Energy efficient monitoring is a monitoring system that uses IoT or IoT-enabled which can monitor electricity consumption with a system to regulate the use of electrical equipment used [10]. Monitoring the use of household electrical appliances to provide information to consumers about electricity consumption so that it can be managed properly [11]. An online monitoring system that is integrated with Power Quality (PQ) and uses virtual instruments and can be widely accessed and utilizes IoT [12].

Research on IoT-based monitoring has been carried out by several researchers. For instance, in 2017, Al-Ali et al. used IoT for the Smart Home Energy Management System. The results showed that users can remotely monitor and control the device and make bills online using a mobile device [1]. In 2018, Despa et al. produced a digital power meter prototype which is used to determine the amount of energy consumption in laboratory based on an IoT technology [8]. In the same year, Chooruang and Meekul developed a monitoring system for voltage, current, active power and overall power consumption [9].

Ramschie et al. (2019) designed a monitoring system for monitoring electricity consumption for Air Conditioning (AC) equipment where the system can monitor and inform the amount of electrical energy consumption and the price paid for operating AC equipment via a smartphone or via a web server [4]. Meanwhile, Pangestu et al in 2019 built a monitoring system that focuses on reading current and power against inductive loads and resistive loads with the Arduino NodeMCU ESP8266. The accuracy rate obtained is in the range of 96% to 99% [5].

In 2020, research on the monitoring system of electric power consumption was carried out by Joshi and Kiran focuses on monitoring power parameters such as voltage, current, frequency, power factor, active power, reactive power, and apparent power and can also predict the power of the appliance and identify the type of device connected [6].

In this study, the monitoring system focused on the current consumption of IoT-based household appliances with the observed equipment, namely light bulb, rice cooker and dispenser. The monitoring process is performed through the web and smartphone. The sensor used is the PZEM-004T

current sensor because it has a high sensor reading accuracy. In addition, NodeMCU is also used, which is an open source IoT platform with the Arduino IDE. This development kit is based on the ESP8266 module which integrates GPIO and PWM

(Pulse Width Modulation). NodeMCU ESP8266 is used as a data processor in this monitoring system. With this monitoring system, users can monitor the electrical power consumption of household appliances more easily.

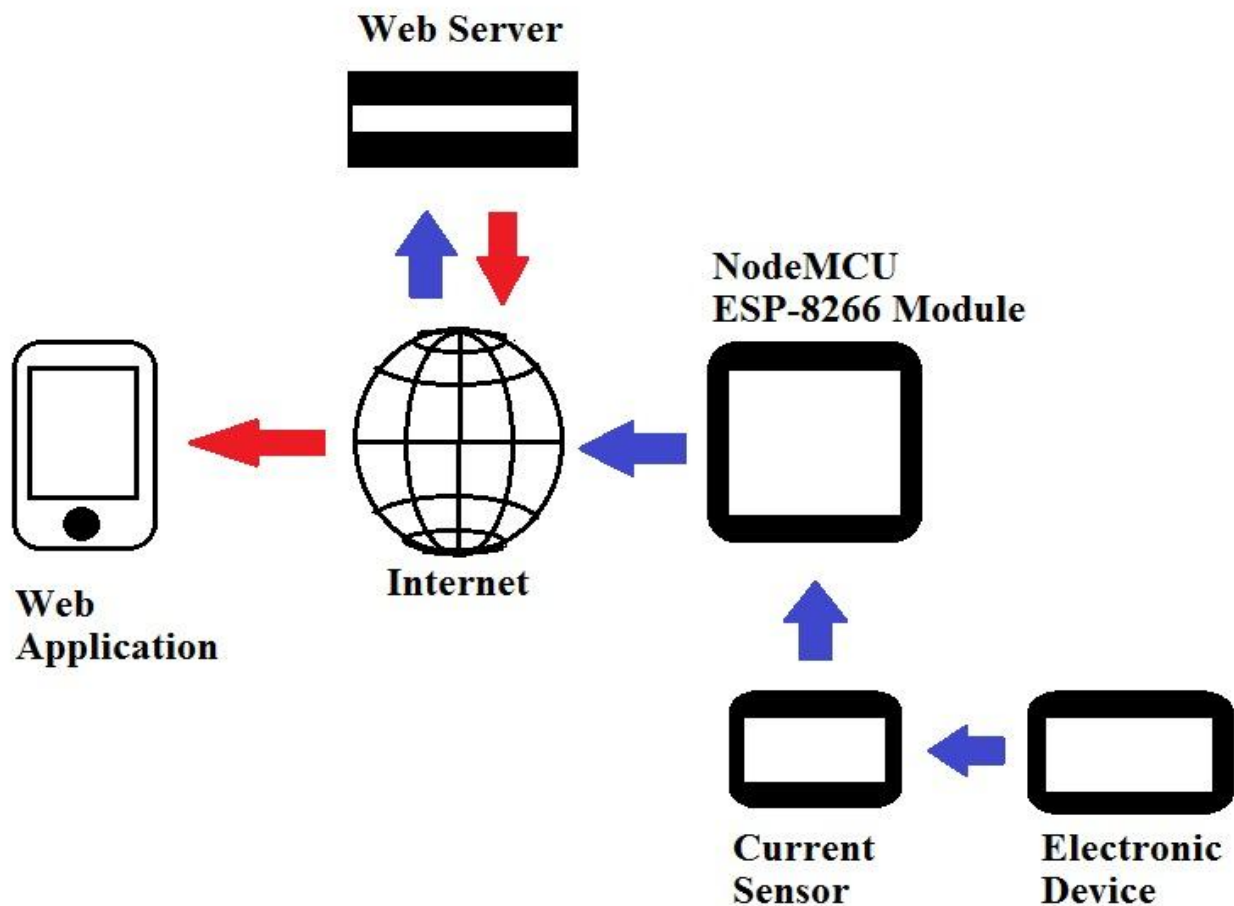

Fig. 1 Schematic diagram of the proposed electrical power consumption monitoring system for a typical smart home

II. PROPOSED IOT ENERGY MONITORING SYSTEM

A schematic diagram of proposed energy consumption monitoring system designed for a typical smart home is shown in Fig. 1. The system is constructed using several devices, namely nodeMCU microcontroller part, sensor PZEM-004T device, web application in the form of personal computer or smartphone, and electronic appliances. The electrical appliances acts as the electrical loads that will be monitored and practically measured to characterize their power consumptions profile during a certain observation period. The sensor reads the electrical power used by the device equipment (load), the value readable on the sensor is sent to the microcontroller. After the data is sent to the microcontroller, it is processed and sent to the webserver using an internet connection. Once the data is received by the webserver, it is stored in a database that can be accessed or monitored through a web application unit.

Each component uses a 5V voltage supply generated from the adapter and is directly connected to the micro USB port on the ESP8266 module. The voltage supply circuit is described in Fig. 2. It consists of a transformer, diode, electrolyte capacitor and IC7805 device. While the circuit connection lay-out of the current consumption monitoring system is illustrated in Fig. 3. The current flow monitoring part exploits the powerful performance of the NodeMCU microcontroller for connection with the internet because the controller equipped with WiFi unit. Through the appropriate programming of the controller to allow the correct set-up and configuration then advanced connection to the specified web server part could be established. The type of sensor used to monitor current consumption is the PZEM-004T sensor. This sensor has several parameters enable to be measured, namely current, voltage, power, power factor, and frequency. PZEM-004T sensor is equipped with a current transformer that serves to convert the

effect of the detected magnetic field on the electrical load system, into an electrical signal that will be processed by the PZEM-004 T sensor into the current and power used in the electrical load. The output of the PZEM-004T sensor is a signal fed to the microcontroller through RX-TX communication between the sensor and the NodeMCU microcontroller.

The characteristics of the PZEM-004T Module are

1. Measure electricity consumption.
2. UART serial interface with a speed of 9600 bps.
3. Supply voltage 5V.
4. Possibility of connecting an LCD or LED screen.

The PZEM-004T Module Parameters specifications according to the datasheet are as follows.

1. Working voltage: 80-260VAC
2. Test voltage: 80-260VAC
3. Rated power: 100A / 22000W
4. Operating frequency: 45 - 65Hz
5. Measurement accuracy: 1.0

The software consists of the ESP 8266 NodeMCU module using the Arduino IDE application and web server software using the PHP programming language and the sublime application as an editor. The computational algorithms of whole electrical power consumption monitoring system (as depicted in Fig.2) programmed at both sensor node terminal and server part are schematically illustrated in Figure 4.

The flowchart diagram described in Figure 4 is an initial system operation called "system setup". In this setup system there is a connection setting to microcontroller connection with WiFi and microcontroller connection with Web Server address used. In addition, there are also variable declarations and initialization of microcontroller ports. Variable declarations include the declaration of voltage, current, and power variables that are the result of readings of the PZEM-004T sensor. While the initialization of microcontroller ports includes naming/initializing microcontroller pins as RX and TX which is a communication line between MCU Node microcontroller and PZEM-004T sensor. After that, the microcontroller scans the PZEM-004T sensor, if the connection to the sensor is successful then the data from the sensor will be stored in the microcontroller's memory. After that, the microcontroller will connect to wifi and web server that has been set at the setup system stage. If you have not connected to the web server, the microcontroller will continue to scan until it is finally connected to the web server. After connecting to the web server, the microcontroller then delivers the data to the webserver, and the webserver receives the data and saves it in the database. Esp disconnects from web server

In WebServer program design, several supporting applications are used, including the Sublime Text application as a Text Editor and the Xampp application to connect to the Database Server. Sublime Text is a Text Editor application used for web design and templates on the website display.

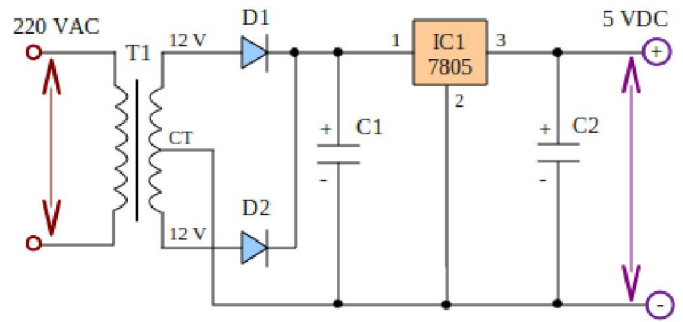

Fig. 2 Power supply circuit

Sublime Text design software includes: connection.php, index.php, reset.php, ACS712.cpp, and get10lastdata.php. This connection.php layer serves to connect the WebServer with the NodeMCU ESP8266 hardware. Any data read on the PZEM-004T current sensor will be displayed in graphical form on the website. In index.php, this layer functions to design the back-end and front-end of the website display. Reset.php functions as a reset button to recalibrate the data displayed on the website. While get10lastdata.php is a function to display the last 10 data from current sensor reading that shows in graphical forms on the website.

The XAMPP application program functions as a local server to handle various types of website data that are in the development process. In practice, XAMPP can be used to test the performance of features or display content on the website without being connected to the internet, or the term offline website. XAMPP works offline just like web hosting.

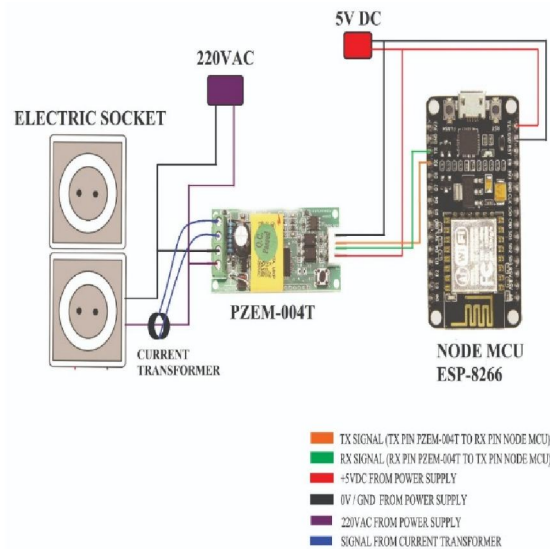

Fig. 3 The circuit connection lay-out of current consumption monitoring system

The XAMPP application program functions as a local server to handle various types of website data that are in the development process. In practice, XAMPP can be used to test the performance of features or display content on the website without being connected to the internet, or the term offline website. XAMPP works offline just like web hosting.

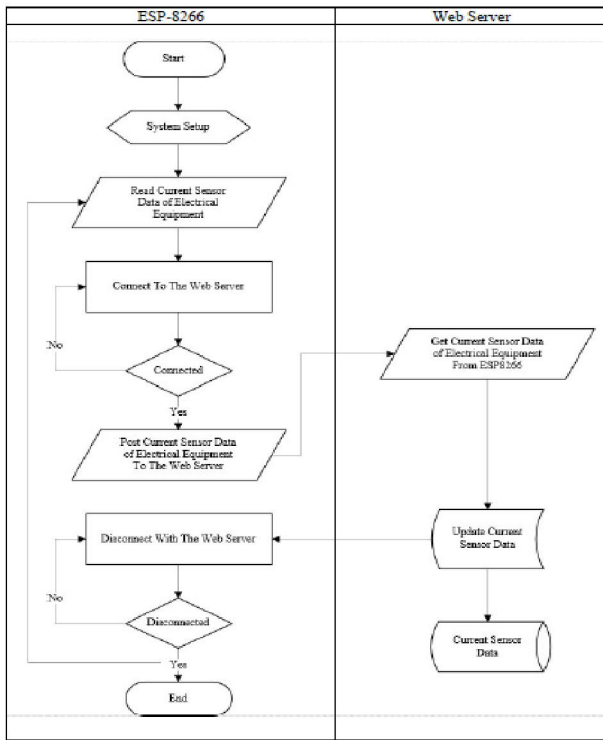

Fig. 4 Flowchart system

III. EXPERIMENTAL TESTING AND DISCUSSION

In this study, the system testing was conducted in three scenarios, namely recording the current and power data of the corresponding electronic appliances that installed and operated at home. The load electrical appliances consist of light bulb, rice cooker and dispenser. Whole system testing steps are described as follows

1. Putting each component in its respective position.
2. Connecting the controller component (ESP 8266) to a 5 Volt DC source.
3. Connecting the load with a voltage source
4. Connecting the Laptop and the ESP 8266 Module to the internet network
5. Accessing a web browser
6. Pressing the button to display the graphic on the web

The results of the proposed electric current consumption monitoring system are shown from Fig. 5 to Fig. 7. The light bulb, rice cooker, and dispenser loads used is 40 Watts, 350 Watts, and 395 Watts, respectively, with a reference voltage of 220 Volts.

Figure 5 shows the results of measuring the light bulb electric current consumption using an ampere meter and sensor for 60 minutes. The ampere meter produces an average value of 0.139 Ampere and the sensor produces an average value of 0.179 Ampere. The theoretical electric current value of the light

bulb used is 0.18 A. The value of the Ampere meter measurement error is 22% and the sensor is 0.5%.

Figure 6 shows the results of measuring the electric current consumption of a rice cooker using an ampere meter and sensor for 60 minutes. The ampere meter produces an average value of 1.48 A and the sensor produces an average value of 1.78 A. The theoretical electric current value of the light bulb used is 1.79 A. The value of the Ampere meter measurement error is 16% and the sensor is 0, 7%.

Figure 7 shows the results of measuring the electric current consumption of the dispenser using an ampere meter and sensor for 60 minutes. The ampere meter produces an average value of 1.37 A and the sensor produces an average value of 1.593 A. The theoretical electric current value of the light bulb used is 1.59 A. The value of the Ampere meter measurement error is 13% and the sensor is 0.6%.

Based on these results, the electric current consumption using the PZEM-004T sensor has an accuracy rate of more than 90% so that the results of monitoring energy consumption are closer to the actual results, namely the results of measurements using a power meter.

Figure 8 shows the results of power consumption of electrical equipment lamps, rice cookers and dispensers. Test results conducted for 60 minutes period showed that light bulb energy consumption approaching to 0.041 kWh. Meanwhile, the rice cooker has the energy consumption of 0.389 kWh and the dispenser has the energy consumption of 0.779kWh, respectively.

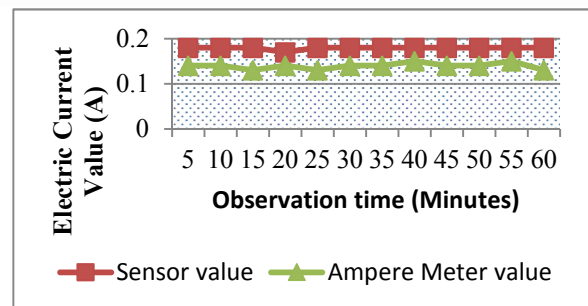

Fig. 5 The result of light bulb load measurement

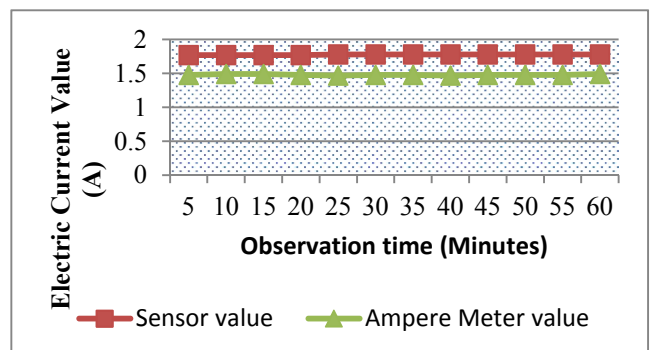

Fig. 6 The result of rice cooker load measurement

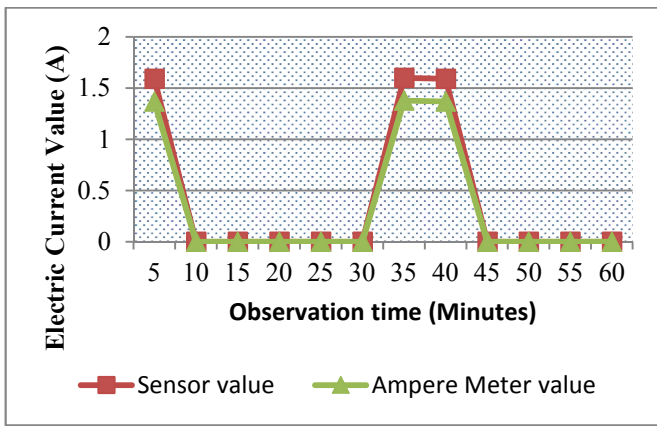

Fig. 7 The result of dispenser load measurement

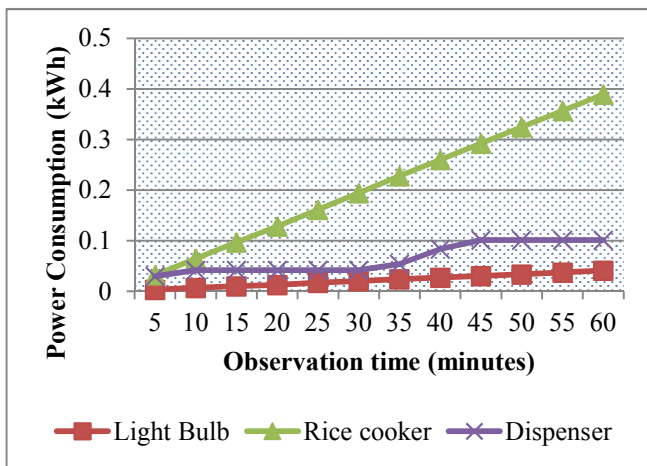

Fig. 8 The result of power consumption

Based on Fig. 5, the average error percentage obtained from the reading of the PZEM-004T sensor on the light bulb load is 0.5%. In measuring the rice cooker load, it is carried out by heating water that is put into the container inside the rice cooker. The error of measuring the current on the rice cooker load is 0.7%. Whereas in Fig.7, it can be seen that from the 10th minute to the 30th minute the current value reads 0 A and at the 45th to 60th minute the current value also reads 0 A. This is because at that minute the dispenser stops heating, so that no electrical load is used. The percentage of error in this measurement is 0.6%.

IV. CONCLUSIONS

The IoT-based electric current consumption monitoring system as a form of utilization of green technology has been carried out in this study. There are 3 electrical appliances that are used as a load, namely light bulb, rice cookers and dispensers. Observations were made for 60 minutes with data transmission every 5 minutes. The results obtained show that the system is successful in monitoring current and power consumption in real-time via a designed web server using a computer or smartphone. In general, the whole electrical power consumption monitoring

system has performed the relatively excellence operational feature for regularly updating the power consumption profile in a particular smart home environment. The monitoring instrument configured provide the high accuracy for abruptly 0.6 %. For future development, an optimization of the monitoring system operational and advancements will be extensively studied.

REFERENCES

- [1] A.R. Al-Ali, I.A. Zualkernan, M. Rashid, R. Gupta, and M. Alikarar, "A Smart Home Energy Management System Using IoT and Big Data Analytics Approach," *IEEE Transactions on Consumer Electronics*, Vol. 63, Issue 4, pp. 426–434, Nov 2017.
- [2] Saji T. Chacko and V. Deshmukh, "IoT based Online Power Consumption Monitoring of a Distribution transformer feeding Domestic/Commercial Consumer loads," on the Proceedings of *2019 IEEE 4th International Conference on Information Systems and Computer Networks (ISCON)*, Mathura, India, 21-22 November 2019.
- [3] S. Joshi and V. Kiran, "Design and Development of Power Monitoring System using IoT Technology," *International Journal of Advanced Science and Technology* Vol. 29, No. 7, (2020), pp. 8128-8138
- [4] A. Ramschie, J. Makal, and V. Ponggawa, "Sistem Pengontrolan Kerja Peralatan Penyejuk Udara Berbasis IoT," On the Prosiding *11th Industrial Research Workshop and National Seminar (IRWNS)* Vol.11 No.1 (2020), Manado, North Sulawesi, Indonesia, pp. 14–19. [in English: IoT Based Electrical Power Consumption Monitoring System for Air Conditioner Equipment]
- [5] A. D. Pangestu, F. Ardianto and B. Alfaresi, "Sistem Monitoring Beban Listrik Berbasis Arduino NODEMCU ESP8266," *Journal Ampere*, Vol. 4, No. 1, pp. 187–197, 2019. p-ISSN 2477-2755 ; e-ISSN 2622-2981 [in English: An Electrical Load Monitoring System Based on ARDUINO NODEMCU ESP8266]
- [6] U. Mudjiono A Subekti and Adiando, "Pembuatan Monitoring dan Audit Energi Untuk Efisiensi Pemakaian Energi Listrik di UPT.PP Politeknik Perkapalan Negeri Surabaya," on the Proceedings of Seminar MASTER 2019, pp. 187–194. ISSN:2548-1509/e-ISSN:2548-6527. [in English: Energy Monitoring and Audit for Efficient Electrical Energy Consumption at UPT. PP Politeknik Perkapalan Negeri]
- [7] A. Ramschie, J. Makal and V. Ponggawa Manado, "Modeling of Energy-Saving Mode Systems on Air Conditioning Equipment," *2018 IEEE International Conference on Applied Science and Technology (ICAST)*, pp. 492–497, 2018.
- [8] D. Despa, G.F. Nama, M.A. Muhammad and K. Anwar "The Implementation Internet of Things (IoT) Technology in Real Time Monitoring of Electrical Quantities," *IOP Conf. Series: Material Science and Engineering* 335 (2018) 012063, ICOMSET, IOP Publishing, pp.1-13.
- [9] K. Chooruang and K Meekul, "Design of an IoT Energy Monitoring System," *2018 16th IEEE International Conference on ICT and Knowledge Engineering (ICT&KE)*, 21-23 November 2018, Bangkok, Thailand, pp. 1–4.
- [10] H. K. H. B. A. S. Kiran, "Towards Efficient Energy Monitoring Using IoT," in *Proceedings of the 21st International Multi Topic Conference, INMIC 2018*, 2018
- [11] D. F. F. A. L. M. P. S. S. Houdi, "Design of an electricity consumption measurement system for Non Intrusive Load Monitoring," *2019 10th International Renewable Energy Congress, IREC 2019*, pp. 1-6, 2019.
- [12] N. N. A. D. A. I. Isdawimah, "Real-Time Monitoring of Power Quality for Web Based Electrical Power Panel Using LabVIEW," in *ICECOS 2019 - 3rd International Conference on Electrical Engineering and Computer Science, Proceeding*, 2019.